

AMERICAN AVK HIGH PRESSURE, 250 PSI, MODERN, DRY BARREL HYDRANT, WITH EXTENDED UPPER BARREL

**27M/PHH/EXT
EXTENDED**

Meets or exceeds AWWA C502 (latest) - Working Pressure - 250 PSI

Inlet Bases: Flanged in accordance with ANSI B16.1 Class 125,

Mechanical and Push-On Joint in accordance with ANSI/AWWA C111/A21.11

Use:

For water and neutral liquids to maximum 160°F.

Tests:

Hydraulic test to AWWA C502:

Seat Test: 500 PSI

Approvals:

UL/ULC Listed,

FM Approved

Certified to:

NSF/ANSI 61

NSF/ANSI 372



Components:

Nozzle Section, Upper Barrel, Barrels, Standpipe Flanges, Breakable Flange, Main Valve Flange, Base, Monitor Elbow

Caps, Weathershield

Nozzles, Valve Seat Ring, Drain Ring
Operating Nut, Thrust Nut

Brass Fittings, Brass Plugs

Main Valve

Stem Rod Couplings, Lock Rings, Nozzle Retaining
Screw, Lock Plate, Lock Plate Screw, Stop Pins,
Coupler Pins, Main Valve Retaining Pin, Spring Pins,

Coating

Stop Nut, Chain Set, Hardware

Barrel Gasket, Cap Gasket, O-rings

Lubrication Hole Seal

Anti-Friction Washer

- | | | | | |
|----------------------------------|---------------------------------|--|-------------------------------------|---|
| Base Elbow / Inlet Configuration | <input type="checkbox"/> 6" MJ | <input type="checkbox"/> 6" Flanged | <input type="checkbox"/> 6" Push-on | <input type="checkbox"/> 6" Hymax Grip® * |
| | <input type="checkbox"/> 4" MJ | <input type="checkbox"/> 4" Flanged | <input type="checkbox"/> 4" PE* | |
| | <input type="checkbox"/> 8" MJ* | <input type="checkbox"/> 6" Straight Flanged | <input type="checkbox"/> 6" PE* | |

*Not UL/ULC Listed or FM Approved

Optional Materials:

- | | | | |
|-------------------------|---|--|--|
| Hardware - Above Ground | <input type="checkbox"/> Zinc Plated (Standard) | <input type="checkbox"/> 304 Stainless | <input type="checkbox"/> 316 Stainless |
| Hardware - Below Ground | <input type="checkbox"/> 304 Stainless (Standard) | <input type="checkbox"/> Zinc Plated | <input type="checkbox"/> 316 Stainless |
| Upper Stem Rod | <input type="checkbox"/> 304 Stainless (Standard) | <input type="checkbox"/> Mild Steel | <input type="checkbox"/> Bronze |
| Lower Stem Rod | <input type="checkbox"/> Mild Steel (Standard) | <input type="checkbox"/> 304 Stainless | <input type="checkbox"/> Bronze |
| Caps, Weathershield | <input type="checkbox"/> Cast Iron (Standard) | <input type="checkbox"/> Ductile Iron | |
| Opening Direction | <input type="checkbox"/> Open Left | <input type="checkbox"/> Open Right | |

Standard:

Ductile Iron ASTM A536

Cast Iron ASTM A126 Class "B"

Bronze

Brass

Ductile iron core, fully encapsulated with EPDM rubber.

Stainless Steel

Above ground-Fusion bonded epoxy inside and out. Below ground - Bitumen/Fusion bonded epoxy. Epoxy meets or exceeds AWWA C550 (latest)

Zinc Plated Steel

NBR - (Barrel Gasket with 304 stainless insert)

Oil Resistant Rubber

Polyamide

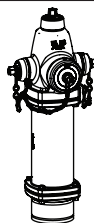

Series 27M/PHH/EXT Extended Upper Barrel
1 Pumper, 2 Hose Outlet

AMERICAN AVK HIGH PRESSURE, 250 PSI, MODERN, DRY BARREL HYDRANT, WITH EXTENDED UPPER BARREL

**27M/PHH/EXT
EXTENDED**

Meets or exceeds AWWA C502 (latest) - Working Pressure - 250 PSI

Inlet Bases: Flanged in accordance with ANSI B16.1 Class 125,

Mechanical and Push-On Joint in accordance with ANSI/AWWA C111/A21.11

Component List:

- | | | | |
|-------------------------------|--------------------------------------|--|--------------------------------|
| 1. Weathershield Bolt | 21. Hose Nozzle Cap Gasket -Detail A | 37. Breakable Stem Rod Coupling | 61. Main Valve Disc -Detail B |
| 2. Weathershield | 22. Hose Nozzle O-ring - Detail A | 38. Spring Pin | 62. Base Gasket -Detail B |
| 3. Lock Plate Screw | 23. Nozzle Retaining Screw | 41. Lower Stem Rod | 67. Base |
| 4. Lock Plate | 24. Chain Set | 44. Extension Bolt -Detail B | 69. Thrust Bearing |
| 5. Inner Thrust Nut O-ring | 25. Pumper Nozzle O-ring | 46. Standpipe Flange -Detail B | 71. Modern Nozzle Section Bolt |
| 6. Thrust Nut | 26. Pumper Nozzle | 49. Lower Barrel | 75. Zerk Fitting |
| 7. Outer Thrust Nut O-ring | 27. Pumper Nozzle Gasket | 50. Lower Barrel O-ring Detail B | |
| 8. Anti-Friction Washer | 28. Pumper Nozzle Cap | 51. Valve Seat Ring -Detail B | |
| 9. Lubrication Hole Seal | 29. Nozzle Section | 53. Valve Seat O-ring -Detail B | |
| 10. Operating Nut | 30. Nozzle Section Bolt | 54. Drain Ring -Detail B | |
| 11. Stop Nut | 31. Nozzle Section Washer | 55. Brass Plug -Not shown | |
| 15. Stem Seal O-rings | 32. Lock Ring | 56. Brass Fitting -Not shown | |
| 16. Upper Stem Rod | 33. Breakable Flange | 60. Main Valve Retaining Pin -Detail B | |
| 17. Barrel Gasket | 34. Nozzle Section Nut | | |
| 19. Hose Nozzle Cap -Detail A | 35. Upper Barrel | | |
| 20. Hose Nozzle -Detail A | 36. Coupler Pin | | |

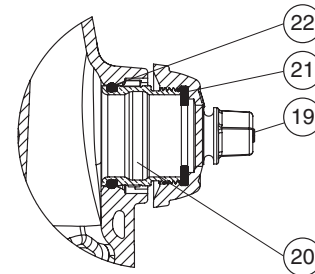
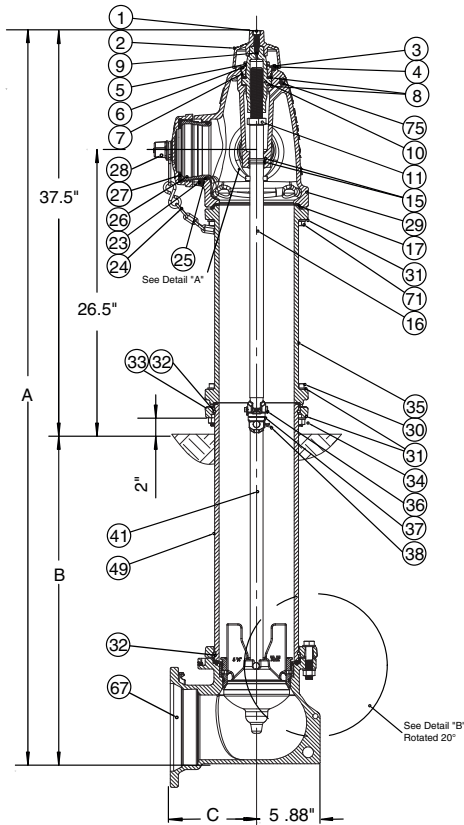

Detail "A"

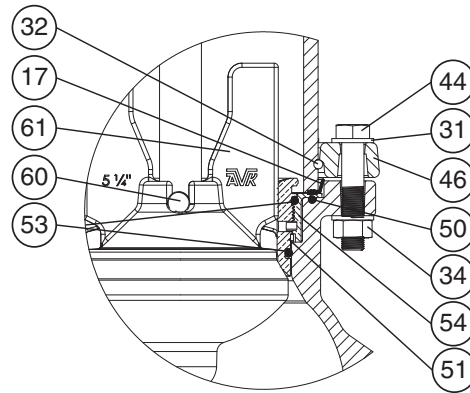

Detail "B"

Ref No.	Base Sizes	Outlets	A	B*	C Flanged	C MJ	C Push-on	C PE	C HYMAX GRIP®
27M-PHH-4-EXT	- 4"	2x2½", 1x4"/4½"	49" - 247"	18" - 216"	8.00"	8.00"	N/A	23.70"	N/A
27M-PHH-6-EXT	- 6"	2x2½", 1x4"/4½"	49" - 247"	18" - 216"	8.00"	8.00"	9.00"	22.80"	11.60"
27M-PHH-8-EXT	- 8"	2x2½", 1x4"/4½"	49" - 247"	18" - 216"	N/A	9.38"	N/A	N/A	N/A

* Buries greater than 216" available upon request.

